

INNOVATORS IN BRUSH TECHNOLOGY

NAMPOWER™

Composite Hub Wheel Brushes

NOW AVAILABLE IN DIAMOND!



Tel: 01707- 327788 | Fax: 01707- 327710
email: sales@pacehigh.co.uk
www.pacehigh.co.uk



Brush Research is pleased to announce our new NamPower diamond wheel brushes for polishing and producing edge radii on hard materials including diamond, CBN, ceramic, carbide, hardened tool steel and glass at a fraction of the price of other diamond wheels on the market. Diamond filament extends brushing technology to enable improvement of hard coatings like plasma sprayed and nitride coated surfaces. The ideal solution for polishing the flute relief on carbide and high speed steel drills, end mills and reamers and producing an edge radius on carbide inserts. Their unique composite hub construction creates brushes that have a much denser and more uniform fill pattern putting more cutting points at the point of attack. Our new diamond filament wheel brushes are available in three diameters: 100mm (4 inches), 150mm (6 inches) and 200mm (8 inches). The 150mm and 200mm diameters come in either 10mm or 15mm face thickness. Our 100mm wheel is available in either a 5mm or 10mm face width to accommodate a variety of flute relief sizes. Our black diamond filament comes standard in 600 mesh which has proven to provide the perfect combination of cutting power and ultra smooth final finish.

www.brushresearch.com

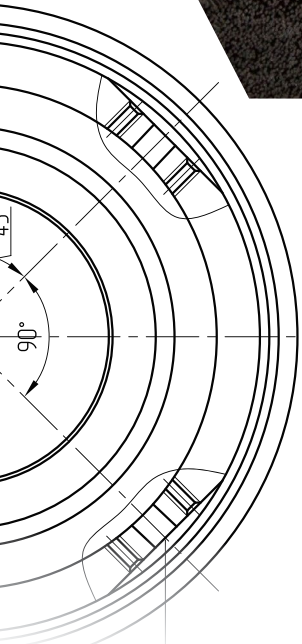

PRODUCT SPECIFICATIONS

PART ID	DIAMETER	FACE WIDTH
DW100X5X600	4"/100mm	5mm
DW150X10X600	6"/150mm	10mm
DW150X15X600	6"/150mm	15mm
DW200X10X600	8"/200mm	10mm
DW200X15X600	8"/200mm	15mm

Diamond Wheel Brushes are made with a 3.25" arbor hole in 150mm and 200mm diameter brushes. Arbor adaptors are available for most common spindle sizes.. 100mm diameter wheels are designed with a 20mm arbor hole.

AVAILABLE IN 600 MESH DIAMOND. ADDITIONAL MESH SIZES ARE AVAILABLE UPON REQUEST.

BENEFITS

Proper edge prep and polishing of flutes on a cutting tool can increase tool life by 200% or more. Micro burrs that form along the edge of the cutting tool create a stress point and potential for further fracture and chipping which will ultimately decrease tool life. Utilizing proper finishing techniques with the NamPower diamond wheel brushes on Carbide, Tool Steel, and Ceramics will reduce the overall potential for chipping and fracture by creating a uniform radius along the edge of the cutting tool. Additionally, the NamPower diamond wheel brushes can be used to polish the flute relief on drills, end mills and reamers to reduce chip loading which results in extended tool life by reducing heat and friction. Controlling the edge radius and polishing flute reliefs will produce a more consistent machining operation and help reduce variation in tool life and tool performance.

APPLICATIONS

TOOLS

- CARBIDE INSERTS
- REAMERS
- END MILLS
- DRILLS
- TAPS
- GEAR HOBS AND SHAPERS

MATERIALS

- HIGH-SPEED STEEL (HSS)
- CERAMIC
- CBN
- CERMET
- TOOL STEEL

EASILY ACHIEVE

- MORE PARTS PER TOOL
- LOWER Ra SURFACE FINISHES
- IMPROVED CUTTING TOOL PERFORMANCE



NAMPOWER DIAMOND WHEEL